

Fotel gamingowy NORD-X2

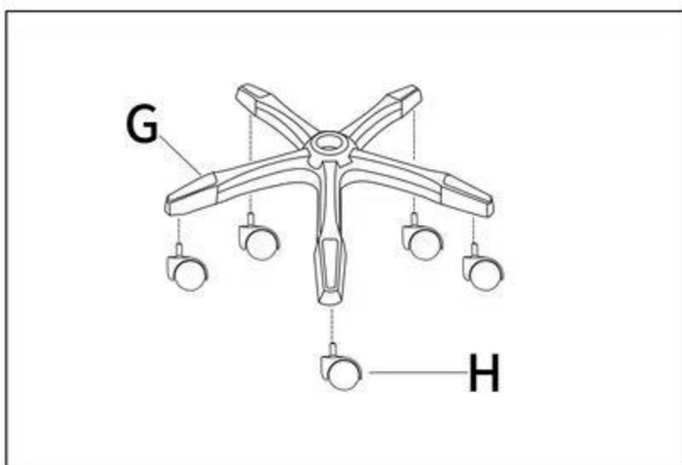

Zamontuj koła do podstawy

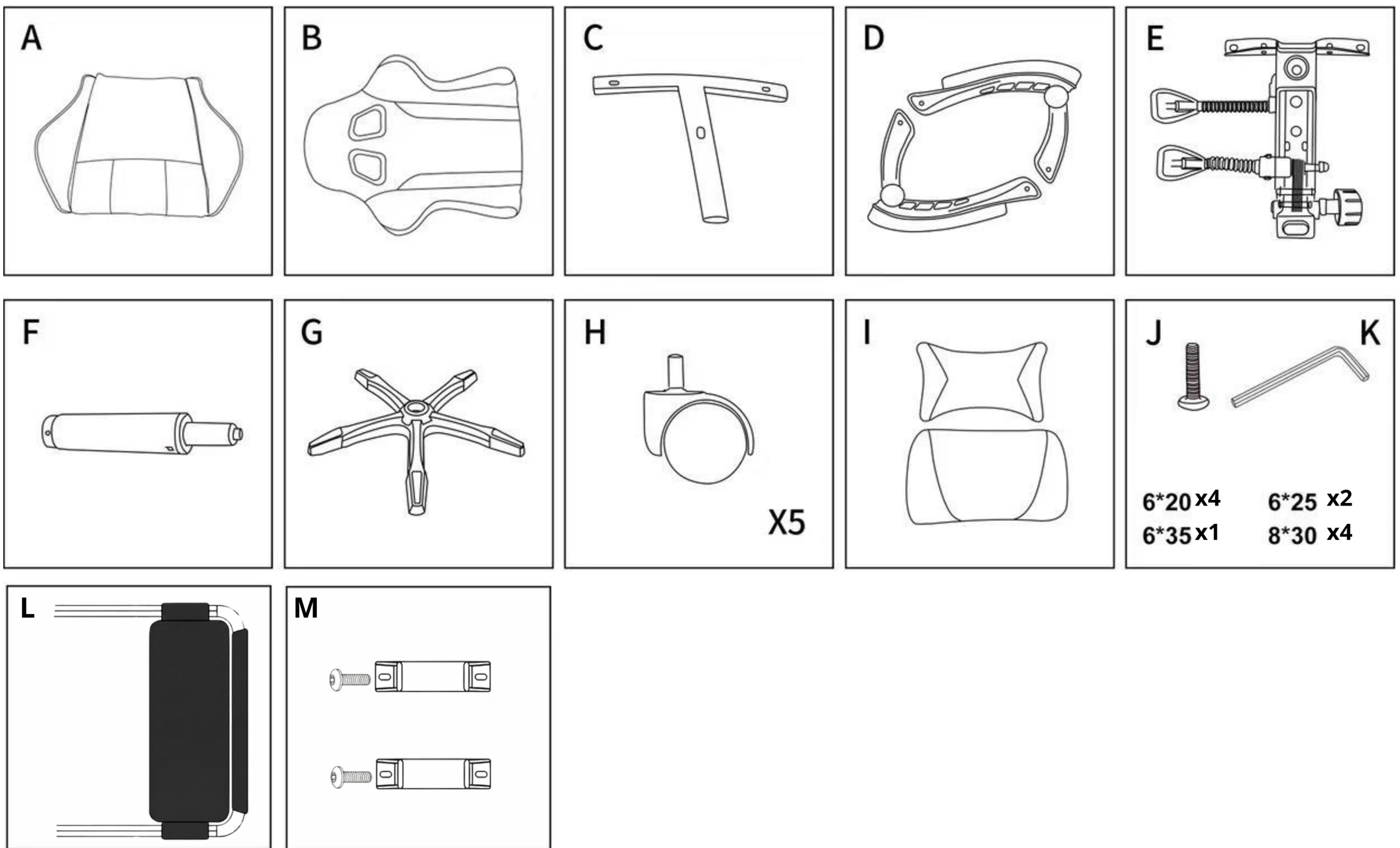
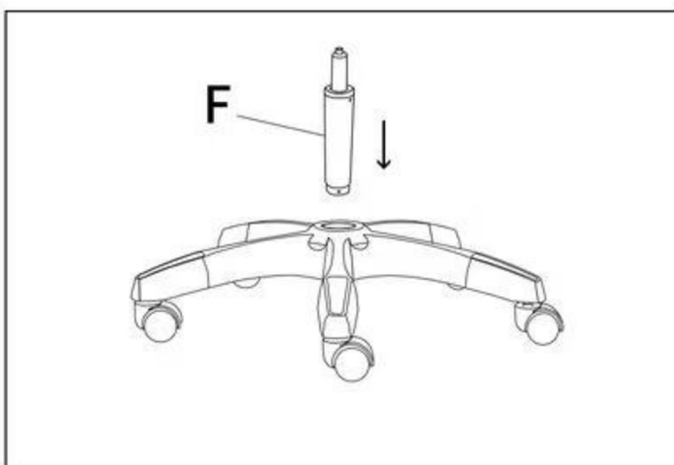

Włóż siłownik gazowy do podstawy z kołami

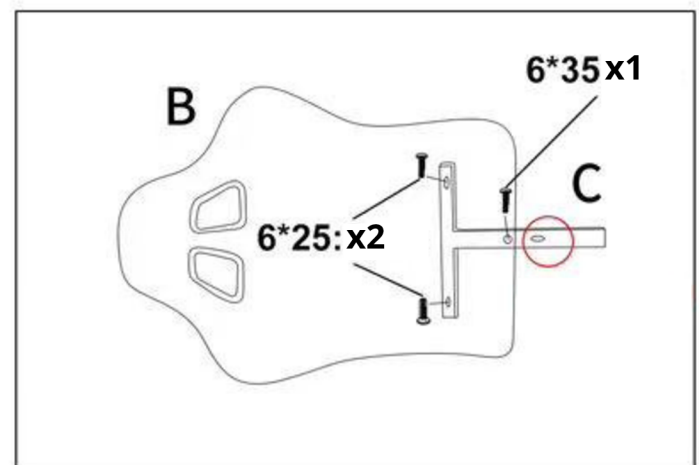

Przymocuj stelaż do oparcia

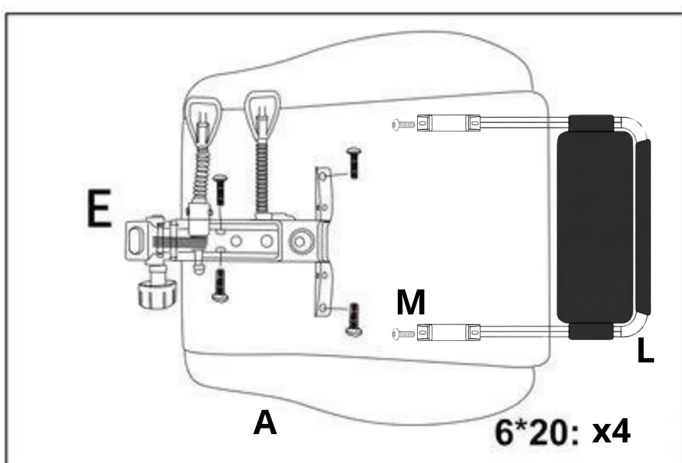

Przymocuj mechanizm od dołu siedziska i zamontuj podnóżek

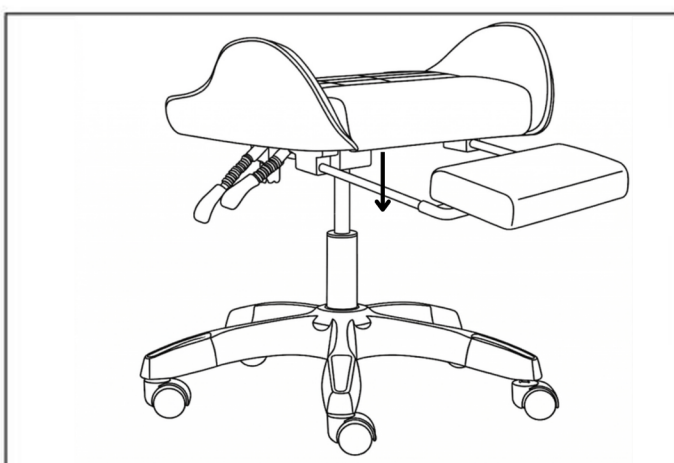

Zamontuj siedzisko z mechanizmem na podstawę



Zamocuj oparcie do siedziska

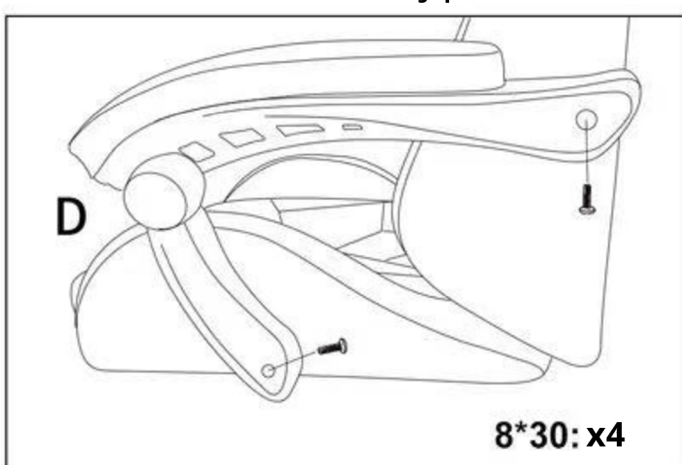

Przymocuj podłokietniki

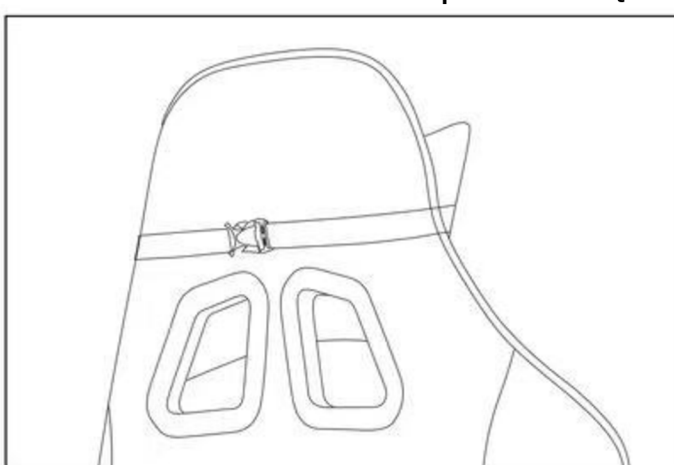

Zamontuj poduszki

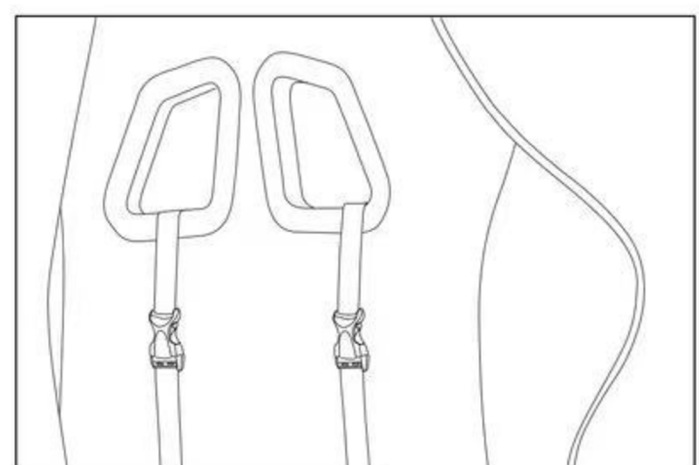

TECHVIKING